

Electrically Operated Roller Blind System

Silent Gliss® 4880

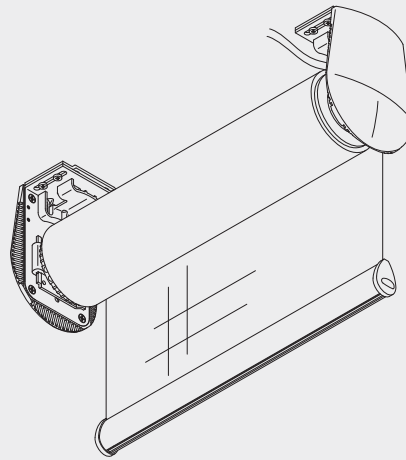

Product Information

- Very heavy duty motorised Roller Blind system. Ideal for contract use
- With Silent Gliss 4880, extremely large windows can be covered by one single motorised system
- Patented Silent Gliss Quick Twist permits easy on-site adjustments of the headrail to minimise fabric roll off (only available on systems up to 4m wide)
- Adjustable stainless steel bracket set: the vertical adjustment facility enables the fabric to be easily aligned with the window frame, or the system with the ceiling on-site using only a screwdriver
- Pre-fitted hook-on stainless steel plates take the weight of the blind during final positioning of the brackets. These are each laterally adjustable sideways by up to 18mm
- The blind is then conveniently fitted from below (especially important in a blind box situation)
- Electronic end stop
- Optional side-guide wires with easy fitting and tensioning
- Bracket covers for neater appearance outside recess
- For systems over 4m wide a 110mm diameter tube is used to minimise bowing (profile 4957)
- Can be combined with Radio Remote Control System Silent Gliss 9940/0450
- Optional Smart motor to allow integration and control by most major home control systems

4880

Profile and Specification Information

Profile 4901 (80mm tube diameter)

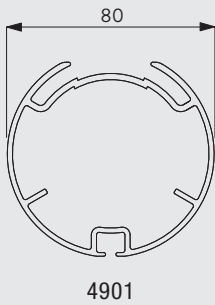

4901

Profile 4957 (110mm tube diameter)

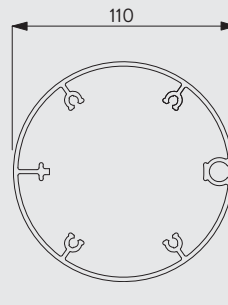

4957

Specification Guide - download from www.silentgliss.co.uk (password required).

Silent Gliss 4880 electrically operated roller blind system for very heavy duty applications. Assembled complete with anodised aluminium headrail and stainless steel bracket combination set 4944 incorporating hook on plates to take weight of blind during fitting. Fix to wall/ceiling/inside recess. Incorporating SG patented QuickTwist for easy on site adjustment of the headrail to prevent fabric roll off. Powered 230V 50Hz motor situated left side incorporating a progressive limit switch unit. Provided with 0615 switch and 0766 in-line connector as standard. Fabrics to be selected from Silent Gliss range.

How to Measure

Measurement information with profile 4901 (80mm tube)

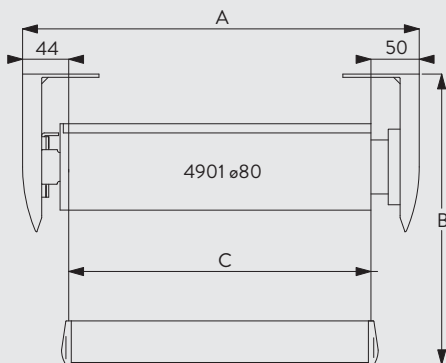

A: system width
B: system drop
C: fabric width

Attention: when installing the blind without bracket covers left and right the total system width will be reduced by 30mm (2 x 15mm)

System measures are indicated with bracket covers. Please refer to Maximum Surface Area Chart for exact total maximum measures of system.

Measurement information with profile 4957 (110mm tube)

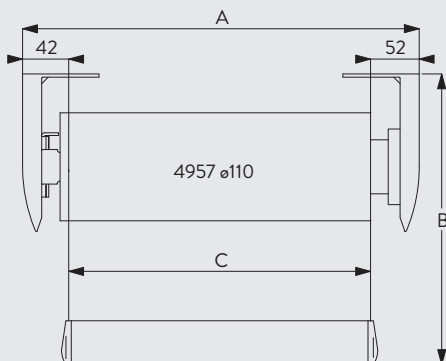

A: system width
B: system drop
C: fabric width

Attention: when installing the blind without bracket covers left and right the total system width will be reduced by 30mm (2 x 15mm)

System measures are indicated with bracket covers. Please refer to Max. Surface Area Chart for exact total maximum measures of system.

System Dimensions

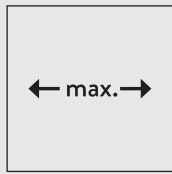

4m with 4901 tube
5m with 4957 tube

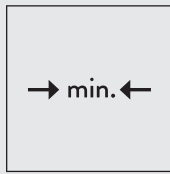

See below:

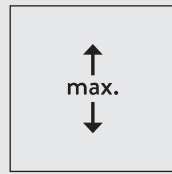

12m with 4901 tube
9m with 4957 tube



36



23kg with 4901 tube
23kg with 4957 tube

Min width:

- Series 20 / Series 40 LV / Smart - 72cm
- Series 40 mains powered 100cm

Maximum surface area chart

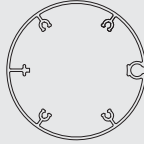
		A →								
		2 m	2.5 m	3 m	3.5 m	4 m	4.5 m	5 m		
B ↓	2 m	●	●	●	●	○	○	○	 ● 4901 (ø 80 mm)	
	2.5 m	●	●	●	●	○	○	○		
	3 m	●	●	●	●	○	○	○		
	3.5 m	●	●	●	●	○	○	○		
	4 m	●	●	●	●	○	○	○	 ○ 4957 (ø 110 mm)	
	4.5 m	●	●	●	●	○	○	○		
	5 m	●	●	●	●	○	○	○		
	5.5 m	●	●	●	●	○	○	○		
	6 m	●	●	●	●	○	○	○		
	6.5 m	●	●	●	●	○	○	○		
	7 m	●	●	●	●	○	○	○		
	7.5 m	●	●	●	●	○	○			
	8 m	●	●	●	●	○	○			
	8.5 m	●	●	●	●	○				
	9 m	●	●	●	●	○				
	9.5 m	●	●	●	●					
	10 m	●	●	●	●					
	10.5 m	●	●	●						
	11 m	●	●	●						
11.5 m	●	●	●	max. 36 m ²						
12 m	●	●	●							

The maximum surface always depends on available fabric widths and fabric weight. As of a width of 4m the system 4880 is supplied with the profile 4957 (110mm tube).

System Options

Side guides for stabilising blind systems and sloped applications (up to 15° incline)

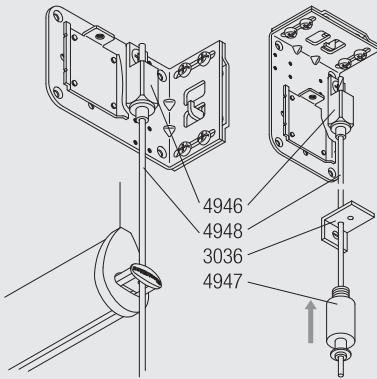

- 4946 Top fastener
- 4948 Wire rope (1.5mm)
- 3036 Bracket
- 4947 Bottom fastener

The bracket 3134 (with cover 3133) can be used as an alternative to 3036 for greater clearance.

Hook-in Installation Plates

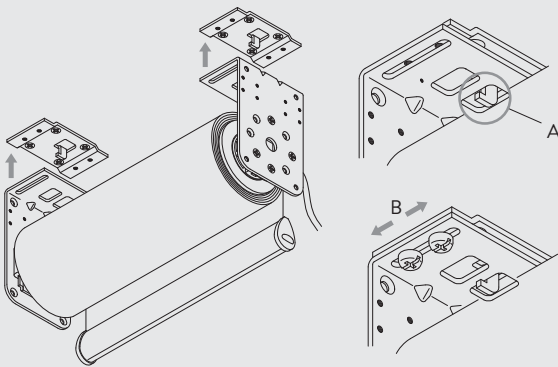

Specially designed pre-fitted hook-in plates 4972 (A) take the weight of the blind whilst the fitters carry out final detailed positioning (B) of the brackets. The brackets can be sideways adjusted by up to 18mm. This unique feature is very well received by all fitters around the world.

Fitting Information

4880

Bracket positioning and basic fitting features

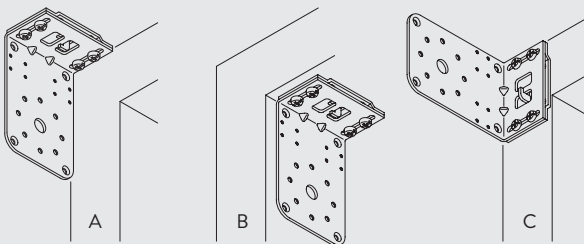

- A: Ceiling fix
- B: Recess fix
- C: Wall fix

Silent Gliss Quick Twist (patented)

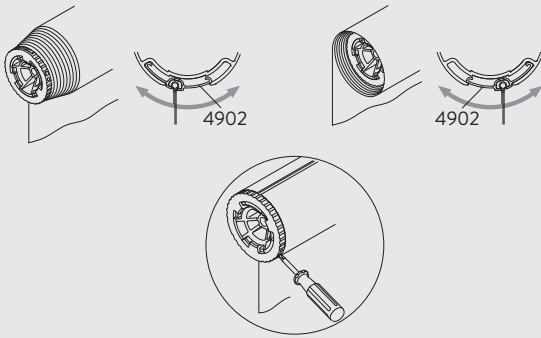

Adjustment feature for fabric rolling off adaptations.

Patented Silent Gliss Quick Twist permits easy on-site adjustments of the heatrail to minimise fabric roll off (only available on systems up to 4m width, using the 80mm tube 4901.)

Hook-in installation plates

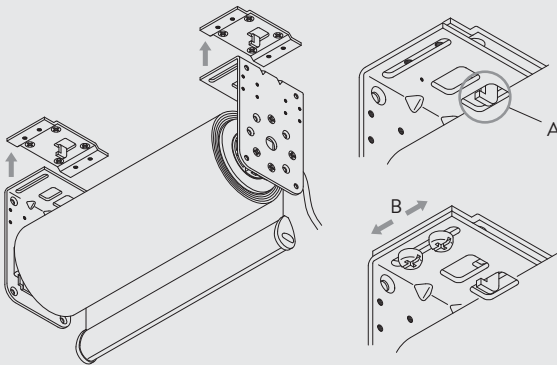

The brackets can be laterally adjusted by up to 18mm.

Specially designed pre-fitted hook-in plates (A) take the weight of the blind during final positioning (B) of the brackets.

Adjustable stainless steel bracket set (for vertical adjustments)

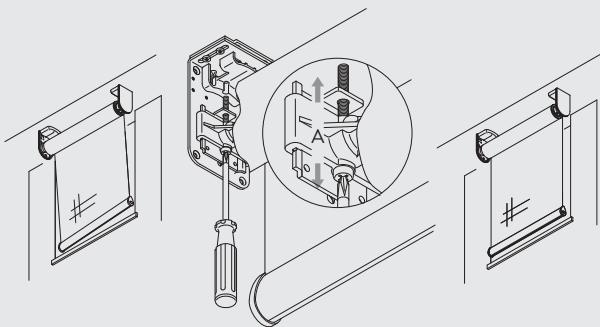

Vertical adjustment of the system (A) allows the headtube to be levelled.

4880

Ceiling fix (profile 4901; 80mm tube)

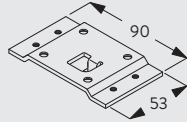
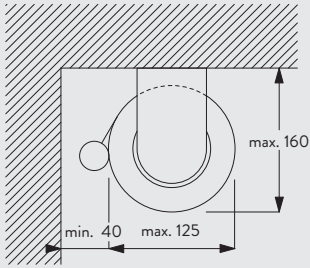

4972
Plate

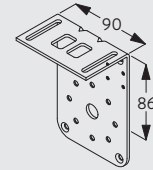

4904
Bracket (131mm)

The fitting key parts shown above are part of bracket set 4949.

Ceiling fix (profile 4957; 110mm tube)

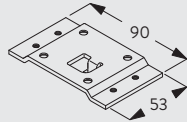
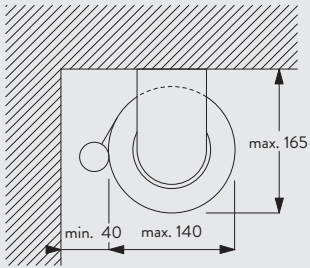

4972
Plate

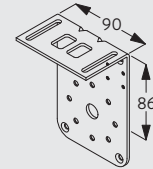

4904
Bracket (131mm)

The fitting key parts shown above are part of bracket set 4949.

Recess fix (profile 4901; 80mm tube)

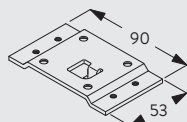
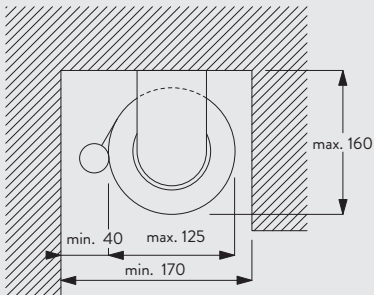

4972
Plate

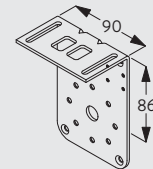

4904
Bracket (131mm)

The fitting key parts shown above are part of bracket set 4949.

4880

Recess fix (profile 4957; 110mm tube)

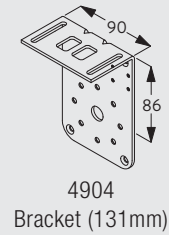
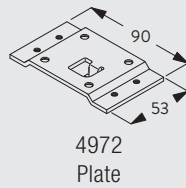
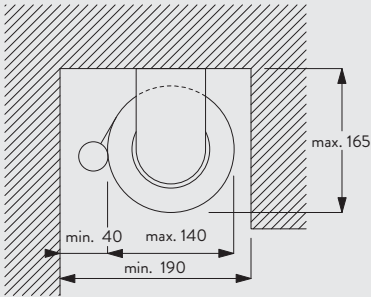

The fitting key parts shown above are part of bracket set 4949.

Wall fix (profile 4901; 80mm tube)

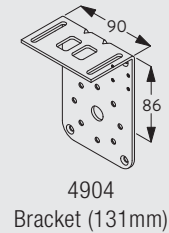
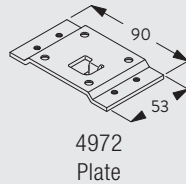
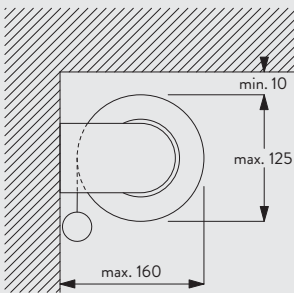

The fitting key parts shown above are part of bracket set 4949.

Wall fix (profile 4957; 110mm tube)

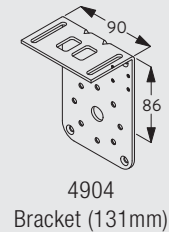
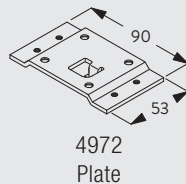
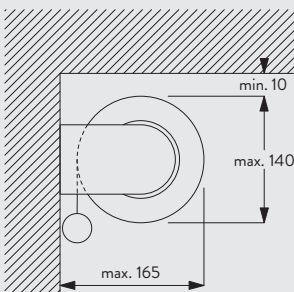

The fitting key parts shown above are part of bracket set 4949.

Standard Accessories

4902 Profile



4903 Bottom bar



4914 Bearing combination



4915 Support



4939 Shaft



4943 Acrylic rod (ø4mm)

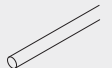

4956	Bracket cover (146mm)		4957	Profile	
4963	Acrylic rod (ø6mm)		9916	In-line connector - complete/no lead (was 0766)	
10326	Motor 20-Series, 230V				

Sets

4949	Bracket set, containing		4904	Bracket (131mm)	2	
			4906	Plate	1	
			4966	Special screw	1	
			4972	Plate	2	

Optional Accessories









0578	Pattress box		0615	Latching switch inc. pattress box	
0997	Motor Test Lead		3036	Bracket (47mm)	
3133	Bracket cover (60mm)		3134	Extension bracket (60mm)	
4946	Wire rope top fastener		4947	Wire rope bottom fastener	
4948	Wire rope (ø 1,5mm)		4951	Steel Rod	
4972	Plate		5741	Klik plug	
5742	Klik socket		11248	Motor 90-230V AC, 40-Series M 10/20, radio receiver	
11249	Motor 24V DC, 40-Series M 10/20		11255	Smart motor 24V DC	
11259	Motor plate M		11260	Smart controller gateway Cedia	
11261	Smart controller gateway KNX		11262	Smart expansion unit	

Supplied by

SG-S | Silent Gliss Spares
Silent Gliss Systems

www.sg-s.co.uk email: sales@sg-s.co.uk tel: 01395 232528

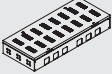
Silent Gliss®

11263	Power supply 24V DC, 2 Ampere DIN Rail		11264	Power supply 24V DC, 3.8 Ampere DIN Rail	
11265	Power supply 24V DC, 5 Ampere DIN Rail		11266	Power supply 24V DC, 10 Ampere DIN Rail	
11281	Cabinet for 8 systems		11282	Cabinet for 24 systems	
11283	Cabinet for 56 systems		11321	Motor drive	
11325	Smart plug 6-pin, MC 1.5/6 ST-3.81				

Motors Silent Gliss 10326 (20 Series)

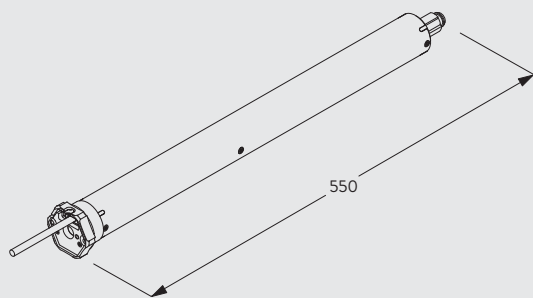

- Voltage: 230V
- Torque: 15Nm
- Speed: 23rpm
- Frequency: 50Hz
- Power: 215W
- Current: 0.95A
- Thermal overload protection
- CE Standard
- Cable pluggable

Operating Methods

Operation via fixed switch with motor 10326

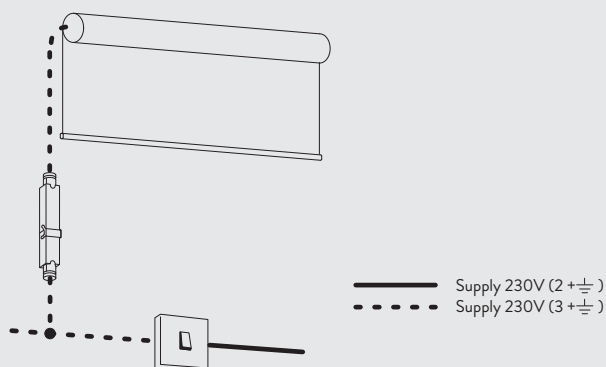

Up to 10 motors can be wired in parallel, cumulative total load must be 25% below the switch/fuse rating.

When using the Fixed Switch control for multiple blinds, when operating simultaneously the blinds may not necessarily stop at precisely the same intermediate point. Top and bottom levels can be preset in alignment. If this is a requirement of the system then we recommend using Series 40 motors or Smart by Silent Gliss.

4880

Radio Remote Control System Silent Gliss 0450.

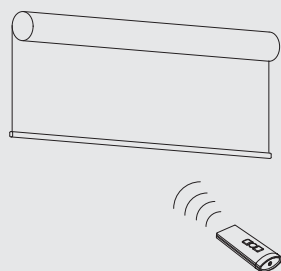

System can be combined with Radio Remote Control system 0450 using motor 10326 with external receiver 0919 and associated transmitters.

Wiring and Connections

Important: Wiring Diagrams are available from www.silentgliss.co.uk (password required).

Motor Silent Gliss 11248/11249 (40 Series)

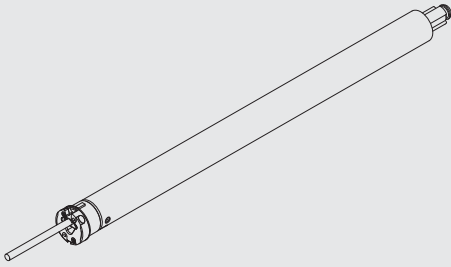

- Motor 11248: Length 812cm
- Motor 11249: Length 499cm
- Motor 11248: 100-240V supply
- Motor 11249: 24V DC supply
- Dry contact switched
- Integrated 9940 radio receiver
- Torque: 10Nm
- Speed: 20rpm maximum (adjustable)
- Current 2.95A

Operating Methods

Radio Remote Control System Silent Gliss 9940

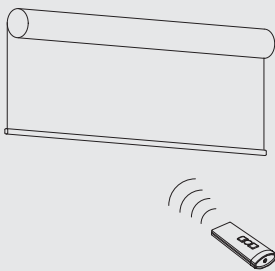

All 40 Series motors include an integrated radio receiver for use with Silent Gliss 9940 control system.

Motors Silent Gliss 11255 (Smart)

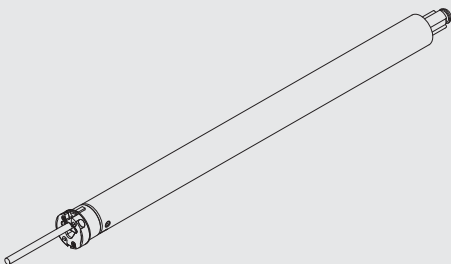

- Smart motor 24V DC
- Smart motor 11255 can be integrated into most major home control systems
- Max speed: 48rpm (adjustable)
- Torque: 1.5Nm
- Must be used in conjunction with Silent Gliss Tateway Controller and associated components.

4880

Supplied by



www.sg-s.co.uk email: sales@sg-s.co.uk tel: 01395 232528

www.silentgliss.co.uk

www.silentglissglobal.com

Silent Gliss Ltd
Pyramid Business Park
Poorhole Lane
Broadstairs
Kent
CT10 2PT
Great Britain

Tel: +44 (0) 1843 863571
Fax: +44 (0) 1843 864503
info@silentgliss.co.uk

Silent Gliss Global Ltd
Pyramid Business Park
Poorhole Lane
Broadstairs
Kent
CT10 2PT
Great Britain

Tel: +44 (0) 1843 874250
Fax: +44 (0) 1843 874457
info@silentglissglobal.com