

**Important**  
 1 single SG9953 unit  
 per motor

**Warning : BS6500 -**  
 Neutral in 4 core flexible  
 cable is now coloured  
 Grey (Previously Blue)

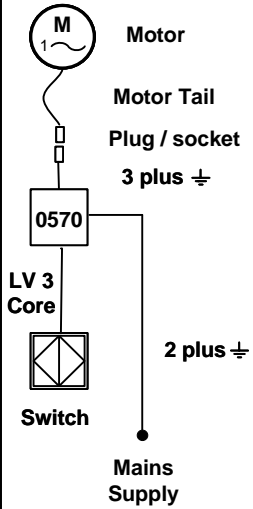

- System Motor Ratings( 230v)**
- SG2195 0.60amp
  - SG2350 0.80amp
  - SG4760 0.80amp
  - SG4770 0.80amp
  - SG4780 0.80amp
  - SG4595 0.80amp
  - SG4960 0.80amp
  - SG4970 0.80amp
  - SG4880 0.90amp
  - SG5800 2.2amp
  - SG8600 0.66amp
  - SG8940 1.00amp
  - SG8800 0.66amp
  - SG8960 0.57amp

**Silent Gliss Ltd**  
 Poorhole Lane.  
 Broadstairs  
 Kent CT10 2PT  
 Tel 01843 863571  
 Fax 01843 864503  
 E-mail: info@silentgliss.co.uk  
 Web site: www.silentgliss.co.uk

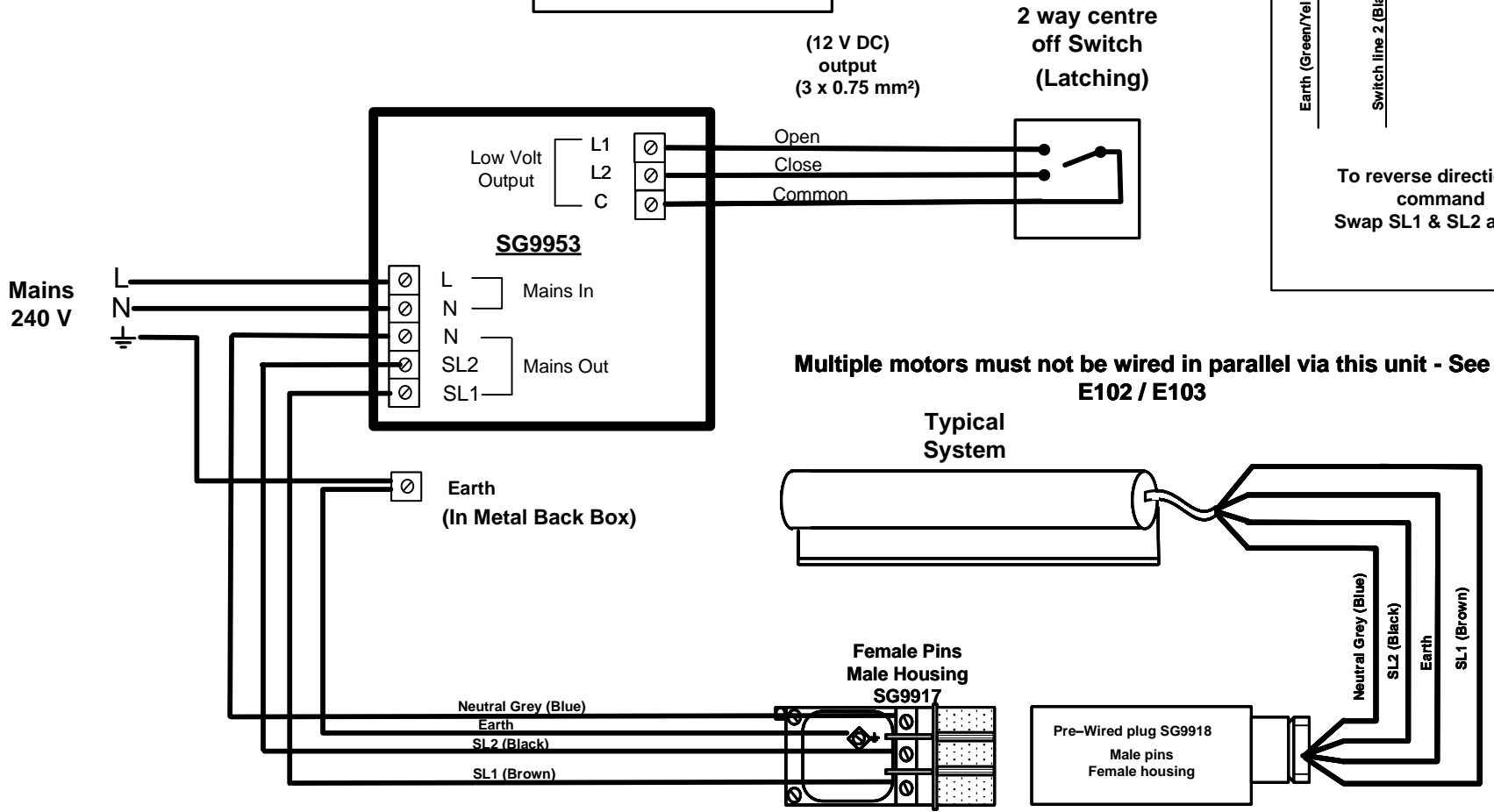

**Multiple motors must not be wired in parallel via this unit - See E102 / E103**

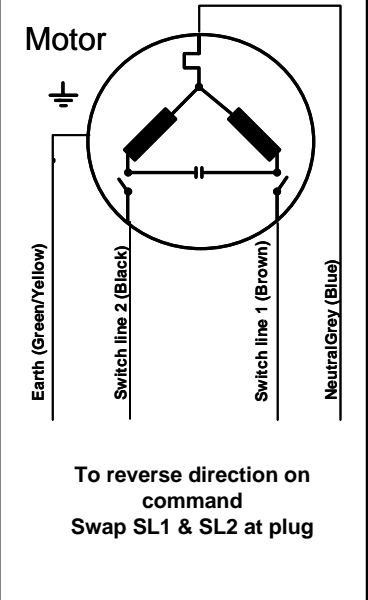

**SG9953 Volt Free Contact Switching Module for 2 Switch live Motors (Series 20)**

**Drawing Number**  
**E122**  
 Issue Date 1/11/19  
 FRO