

SG0913
single channel switch

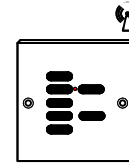

SG0914
8 channel Fixed switch



SG0915
single channel remote control



SG0336
multi channel remote control

Warning : BS6500
 - Neutral in 4 core flexible cable is now coloured Grey (Previously Blue)

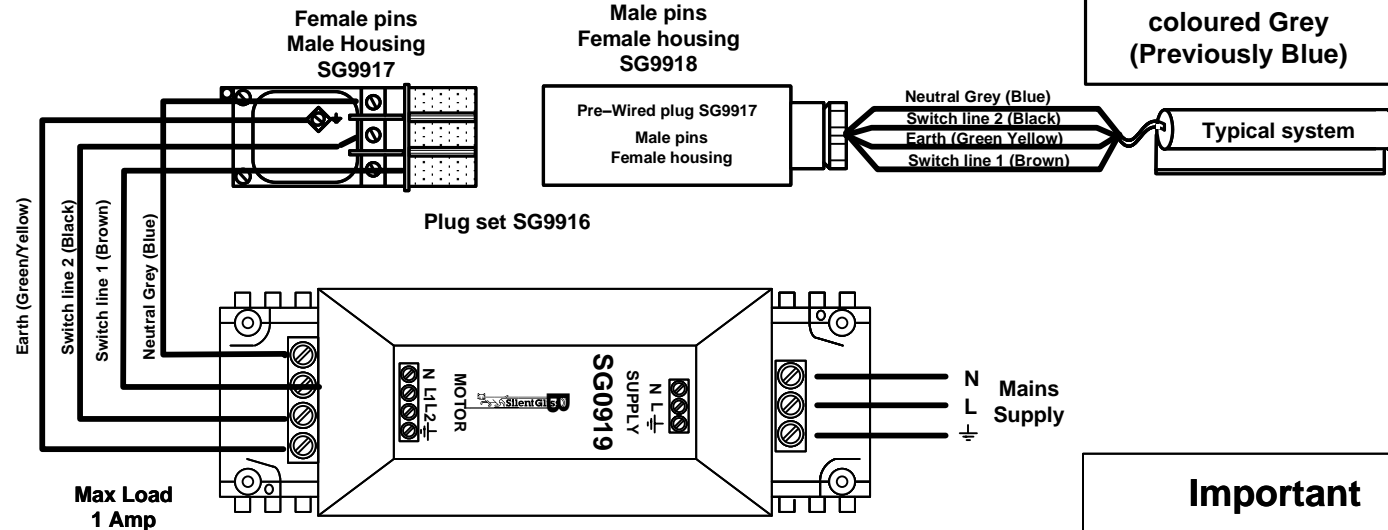

Notes

See separate instructions for setting up address codes.

Systems SG8800 & SG8960- Module must be factory pre-programmed. A label will be attached to pre-programmed modules

Do not connect more than one motor to each Module SG0919. Modules act to prevent feedback between motors as well as switching

Important
 Plug / socket must be wired correctly with exposed pins on SG9917 fitted to motor tail

Silent Gliss Ltd
 Poorhole Lane.
 Broadstairs
 Kent CT10 2PT
 Tel 01843 863571
 Fax 01843 864503
 E-mail: info@silentgliss.co.uk
 Web site: www.silentgliss.co.uk

Silent Gliss Radio Control System SG0450 - Module SG0919
Systems SG2195, SG2350 (Series 20), SG4760/70/80 (Series20),
SG4960/70/SG 4880 (Series 20) SG5800, SG8600, SG8640
,SG8960

Drawing Number

E 202

Issue Date 10/8/21
FRO