

Mains Supply  
90 – 260v AC

Maximum 3 motors  
simultaneous  
recommended.

Above 3 motors a  
competent  
electrician should  
be consulted to  
ensure wiring is  
suitable.

**Motor Rating**

0.5 A @ 230 V  
1.0 A @ 115 V

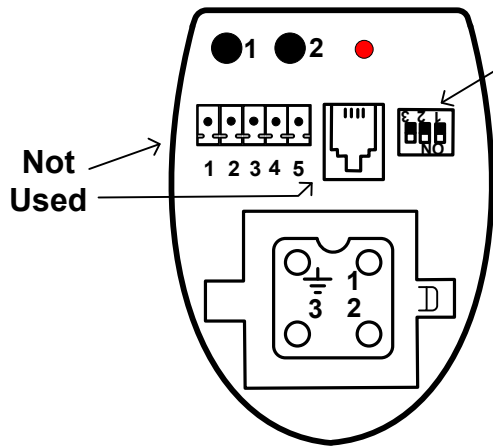

1 = ON  
2 = OFF  
3 = OFF

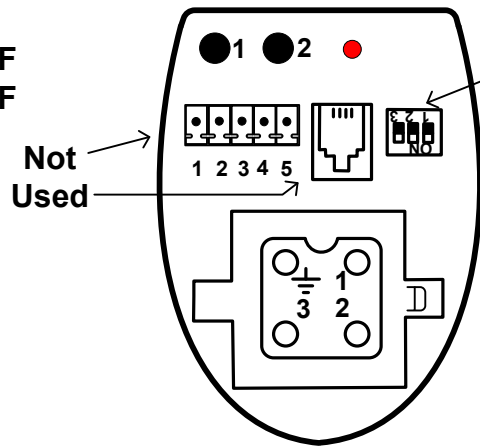

1 = ON  
2 = OFF  
3 = OFF

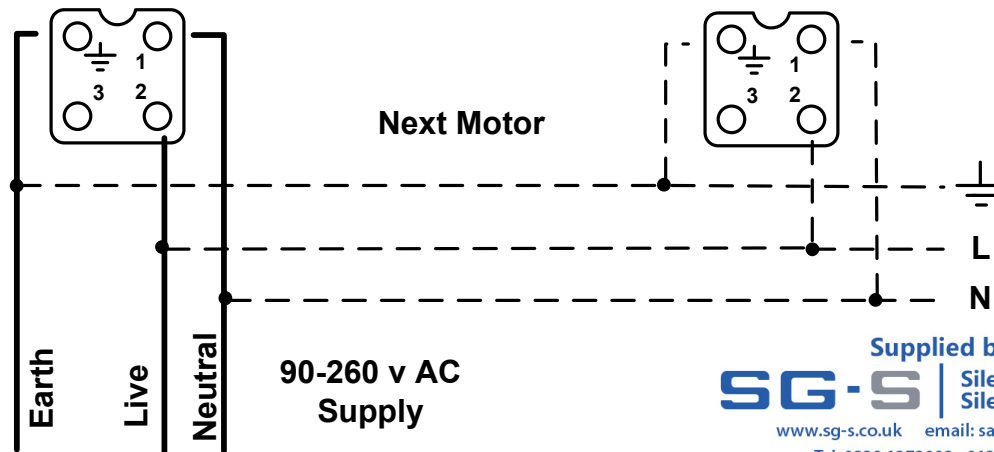

Transmitters

Switches

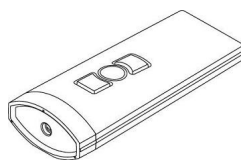

10300

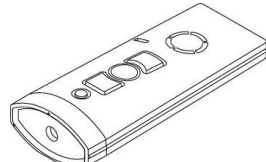

10302

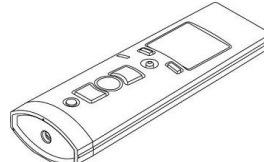

10303

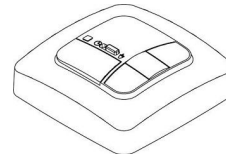

9943

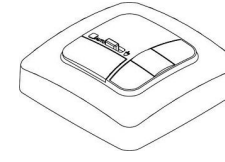

9946

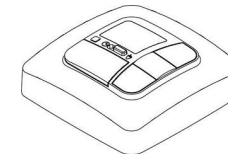

9948

Refer to separate instructions for set-up and commissioning of radio controls

Supplied by  
**SG-S** | Silent Gliss Spares  
Silent Gliss Systems  
www.sg-s.co.uk email: sales@sg-s.co.uk  
Tel: 0330 1272002 - 01395 232528

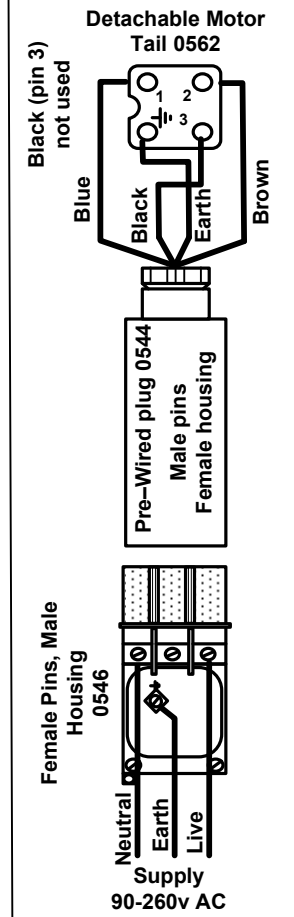

**Silent Gliss Ltd**  
Poorhole Lane.  
Broadstairs  
Kent CT10 2PT  
Tel 01843 863571  
Fax 01843 864503  
E-mail: info@silentgliss.co.uk  
Web site: www.silentgliss.co.uk

**Silent Gliss Radio Control System 9940**  
**Systems 5400R & 5420R**  
**Motor 9021E with Integrated Radio Control**

**Motor Type BB**  
**Drawing Number**

**E 607**

**Issue Date 03-03-10**