



Cable Types To Motors



Motor Power	
M+ 24Vdc	Red 16 AWG
M- 0V	Black 16 AWG
Motor Data	
D+ Data +	Purple 22 AWG
D- Data -	White 22 AWG

To Power Supplies



Power Source	
Vin 24Vdc	Red 18 AWG
0V 0V	Black 18 AWG

Power Supplies

- SG11263 24v DC 2amps **
- SG11264 24v DC 3.8amps
- SG11265 24v DC 5amps
- SG11266 24v DC 10amps
- ** Required for Gateway Always

Motor ratings

- SG 4960 1.8amps 24v DC
- SG4760,4770,4780,4970 1.5 amps 24v DC
- SG2350 2.1 amps 24v DC
- SG4880 2.95 amps 24v DC
- SG5600 3.5amps 24v DC

Silent Gliss Ltd
 Poorhole Lane.
 Broadstairs
 Kent CT10 2PT
 Tel 01843 863571
 Fax 01843 864503
 E-mail: info@silentgliss.co.uk
 Web site: www.silentgliss.co.uk

6 Way Pluggable connector for blinds and curtain tracks

If the distance from Motor to Gateway is Greater than 55M please refer to Silent Gliss Cable Distance Table.

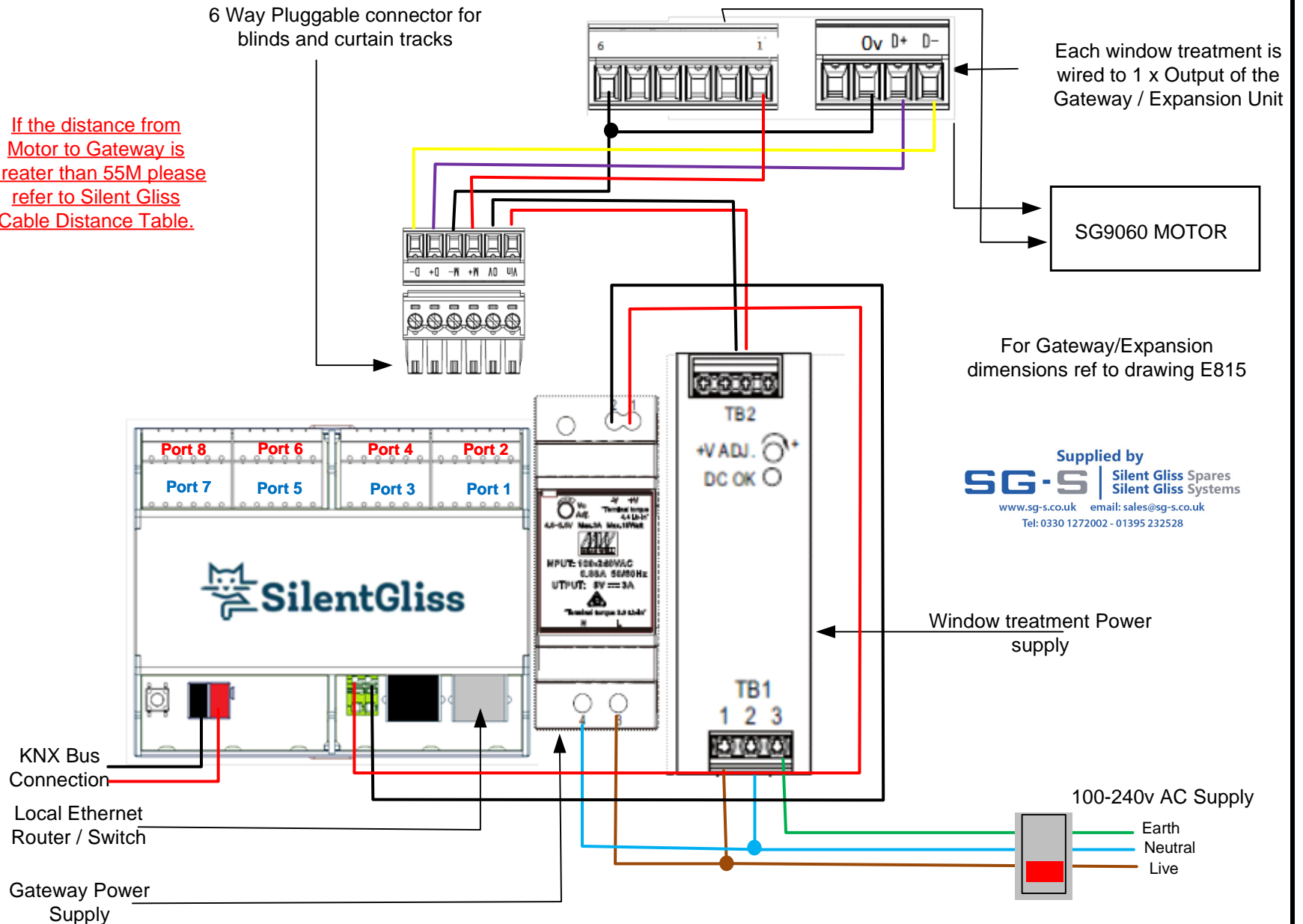

Each window treatment is wired to 1 x Output of the Gateway / Expansion Unit

SG9060 MOTOR

For Gateway/Expansion dimensions ref to drawing E815

Supplied by
SG-S Silent Gliss Spares
 Silent Gliss Systems
 www.sg-s.co.uk email: sales@sg-s.co.uk
 Tel: 0330 1272002 - 01395 232528

Window treatment Power supply

100-240v AC Supply
 Earth
 Neutral
 Live

Smart by Silent Gliss- Gateway SG11260

Systems: Smart-SG5600,SG7650

Drawing Number

E 801/2

Issue Date

27/9/22