



Cable Types To Motors



Motor Power	
M+	24Vdc Red 16 AWG
M-	0V Black 16 AWG
Motor Data	
D+	Data + Purple 22 AWG
D-	Data - White 22 AWG

To Power Supplies



Power Source	
Vin	24Vdc Red 18 AWG
0V	0V Black 18 AWG

Power Supplies

- SG11263 24v DC 2amps **
 - SG11264 24v DC 3.8amps
 - SG11265 24v DC 5amps
 - SG11266 24v DC 10amps
- ** Required for Gateway Always

Motor ratings

- SG 4960,4760,4770,4780,4970
1.5 amps 24v DC
- SG2350 1.5 amps 24v DC
- SG4880 2.95 amps 24v DC
- SG5600 3.5amps 24v DC

Silent Gliss Ltd
 Poorhole Lane.
 Broadstairs
 Kent CT10 2PT
 Tel 01843 863571
 Fax 01843 864503
 E-mail: info@silentgliss.co.uk
 Web site: www.silentgliss.co.uk

Available from
SG-S Silent Gliss Spares
 Silent Gliss Systems
 www.sg-s.co.uk email: sales@sg-s.co.uk
 Tel: 0330 1272002 - 01395 232528

If the distance from Motor to Gateway is Greater than 55M please refer to Silent Gliss Cable Distance Table.

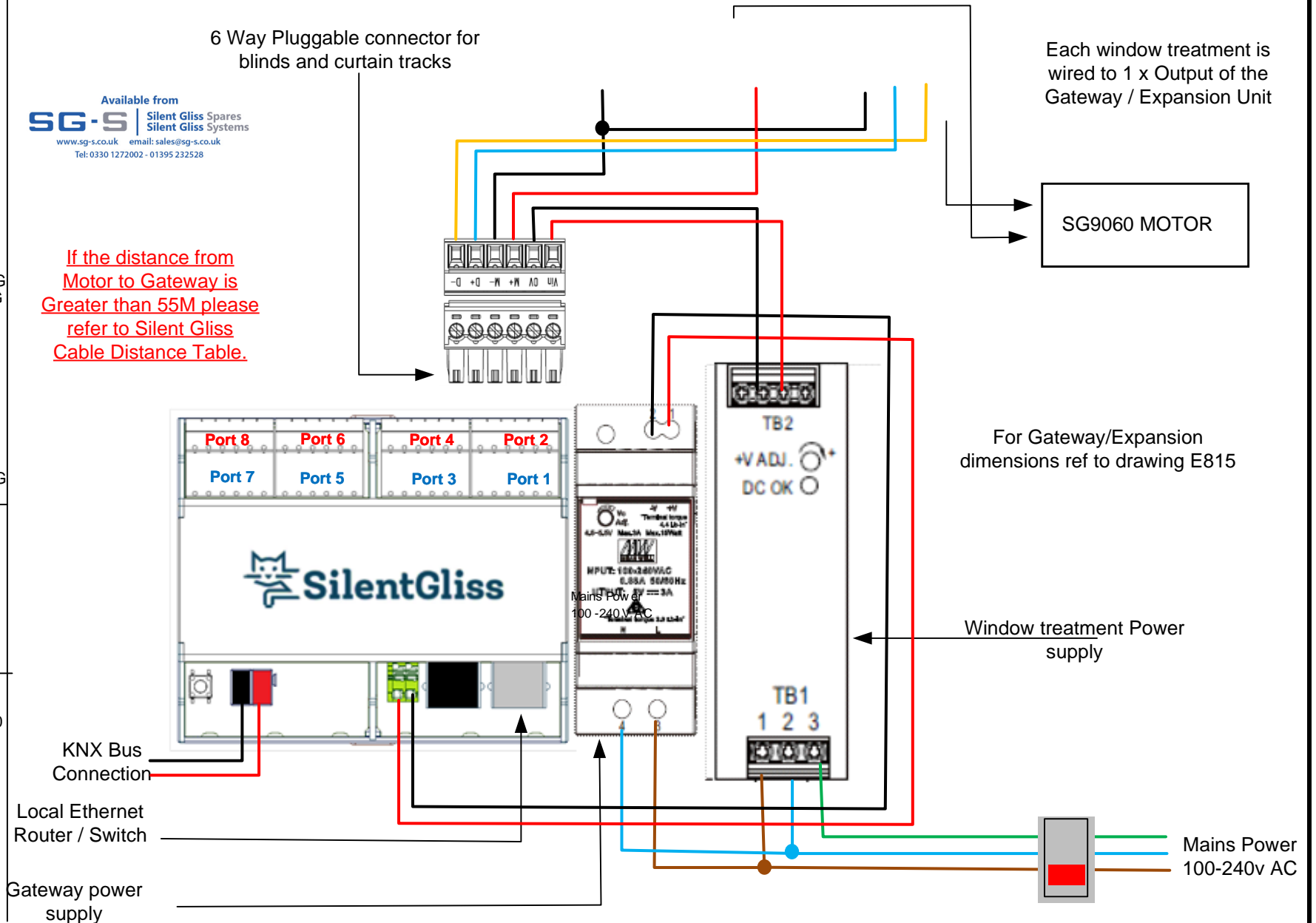

Smart by Silent Gliss- Gateway KNX SG 11261 Track Systems

Systems: SG 5600 & SG 7650

Drawing Number

E 803-2

Issue Date 24/10/22 FRO