

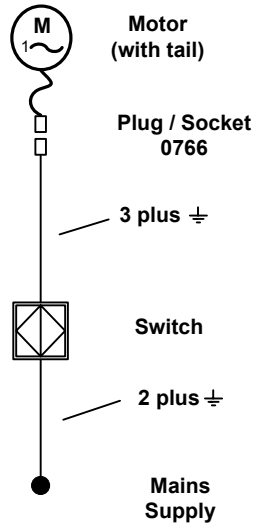

All printed & electronically distributed copies of this drawing are uncontrolled copies



Motor Ratings

	230v	115v
9010	0.6A	1.2A
9011	0.6A	1.2A
5360	0.82A	1.75A

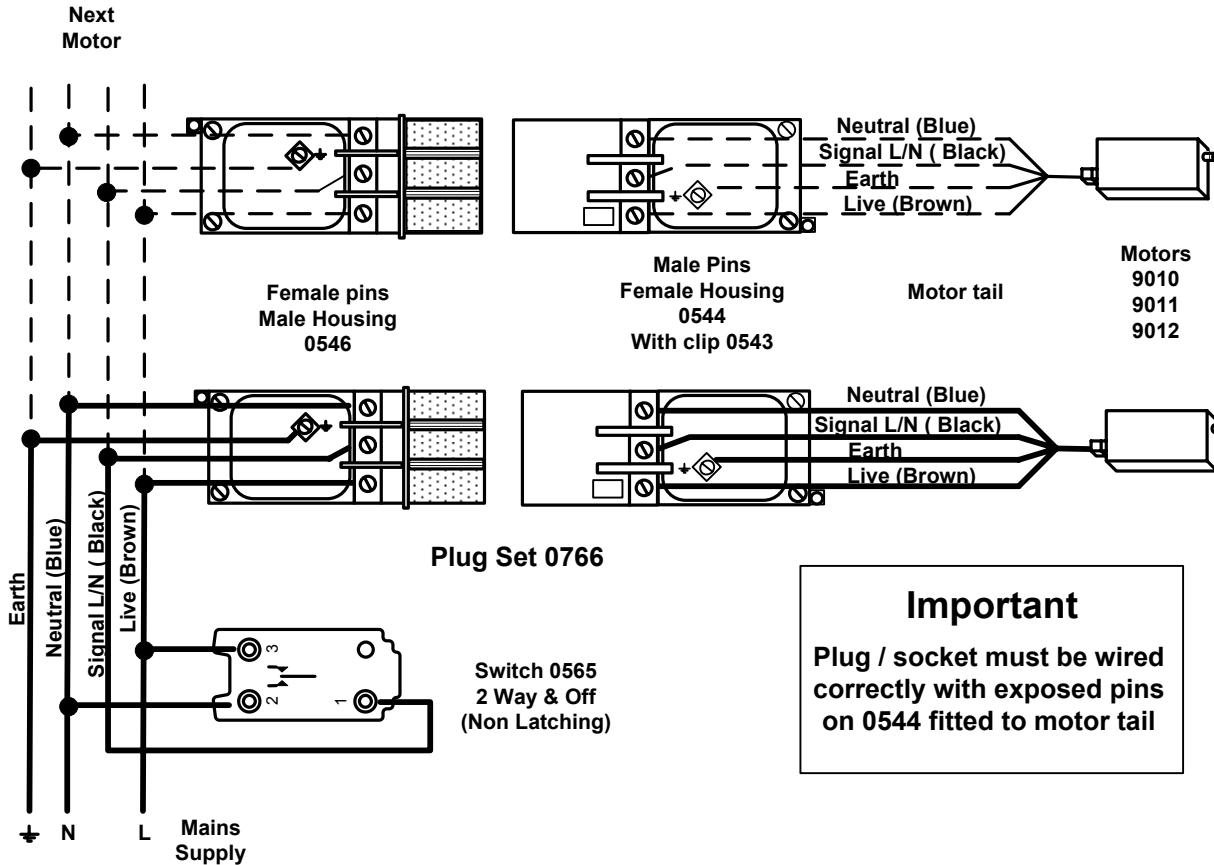

Important
Plug / socket must be wired correctly with exposed pins on 0544 fitted to motor tail

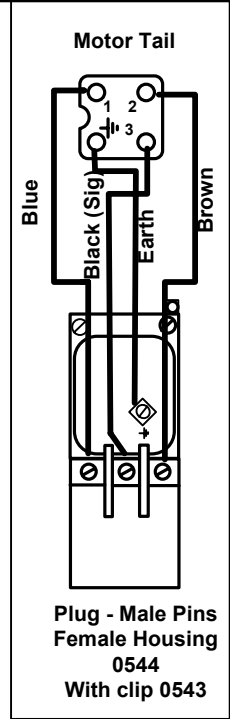

Can also be used in conjunction with other methods of control. See Drawings:
E902 - Individual and/or Simultaneous from 1 or more switches via Low Voltage
E904 - Connection to LON systems

Note - Systems 2650 & 2950 require individual control to ensure alignment of louvers when in banks



Silent Gliss Ltd
Poorhole Lane.
Broadstairs
Kent CT10 2PT
Tel 01843 863571
Fax 01843 864503
E-mail: info@silentgliss.co.uk
Web site: www.silentgliss.co.uk

**1 Mains Switch - 1 or more Motors (9010, 9011, 5360)
Simultaneous only
Systems 2050 2500 2650 2950 5100 5140 5150 5300**

See E910 for systems 2050, 2500, 5100, 5140 with Motor 9012

Motor Type A & &
Drawing Number

E 901

Issue Date 21-8-06