

Motor Rating @ 230v
 5360 = 0.82A

Motor DIP switches to be set up for motor non latching
 1=off 2=on 3=off 4=on

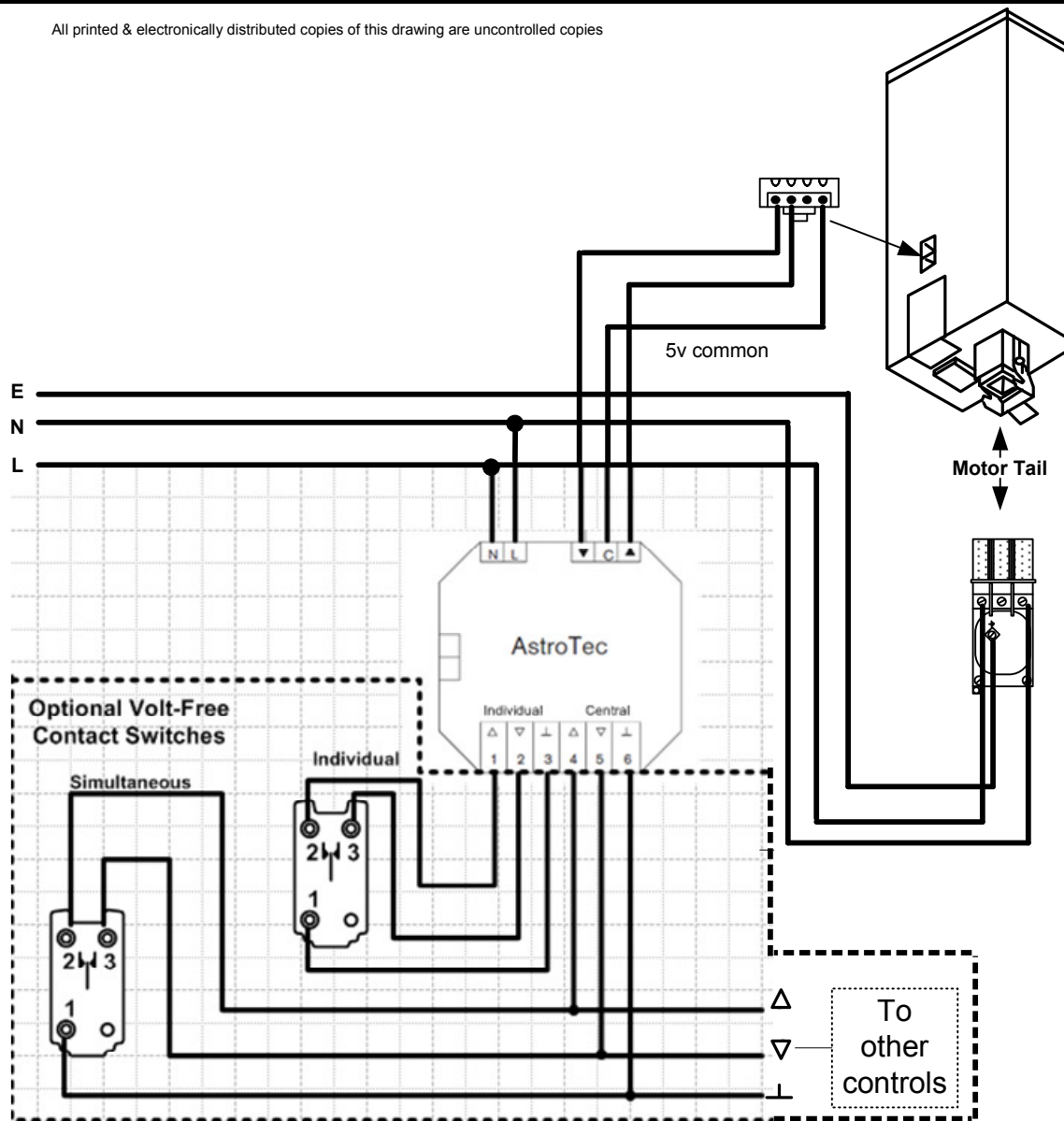

Important
 Plug / socket must be wired correctly with exposed pins on 0544 fitted to motor tail

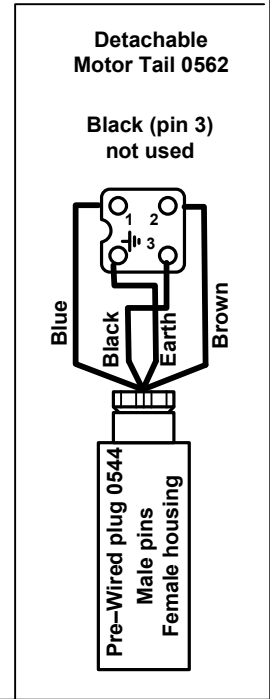

Silent Gliss Ltd
 Poorhole Lane.
 Broadstairs
 Kent CT10 2PT
 Tel 01843 863571
 Fax 01843 864503
 E-mail: info@silentgliss.co.uk
 Web site: www.silentgliss.co.uk

Timer control of 5360 Motor using 9952 Timer

Drawing Number

E 909

Issue Date 03-03-10